

BER Analysis of Massive MIMO Systems based on Non-Cooperative Cognitive Radio Network

Dr. Rammilan Chadhar

Assistant Professor

Department of Electronics and Communication Engineering

Madhyanchal Professional University, Bhopal

Email - rammilanchadhar@gmail.com

Abstract: In a cellular network, the demand for high throughput and reliable transmission is increasing in large scale. One of the architectures proposed for 5G wireless communication to satisfy the demand is Massive MIMO system. The massive system is equipped with the large array of antennas at the Base Station (BS) serving multiple single antenna users simultaneously i.e., number of BS antennas are typically more compared to the number of users in a cell. This additional number of antennas at the base station increases the spatial degree of freedom which helps to increase throughput, maximize the beamforming gain, simplify the signal processing technique and reduces the need of more transmit power. The advantages of massive MIMO can be achieved only if Channel State Information (CSI) is known at BS uplink and downlink operate on orthogonal channels. The studied of non-cooperative cognitive radio network based massive MIMO systems is present in this paper.

Key Words: Spectrum Sensing, Cognitive Radio, Non- Cooperative Communication, Massive MIMO.

1. INTRODUCTION:

The number of wireless devices and new mobile users has led to an exponential rise in the demand for wireless throughput over the past few years [1]. The throughput is the result of Transmission capacity (Hz) and Ghostly effectiveness (bits/s/Hz). Bandwidth or spectral efficiency must be increased to increase throughput. Since expanding the Data transfer capacity is an expensive component, the phantom productivity must be thought about. It very well may be expanded by utilizing various radio wires at the transmitter and recipient. Numerous Info Various Result (MIMO) radio wires improve both correspondence dependability as well as the limit of correspondence (by sending various information in various radio wires).

For the most part MIMO frameworks are isolated into two classifications: Multi User-MIMO (MU-MIMO) and Point-to-Point MIMO are two examples [2, 3]. In Highlight Point MIMO, both the transmitter and collector are furnished with different recieving wires. The exhibition gain can be accomplished by utilizing the procedures, for example, beamforming and spatial multiplexing of a few information streams. The wireless channel, on the other hand, is shared spatially between users in MU-MIMO. The clients in the cell communicate and get information without joint encoding and joint recognition among them. By making use of the distinct spatial signatures that are present at the BS antenna array, the Base Station (BS) is able to communicate with all of the users simultaneously. MIMO frameworks are consolidated in a few new age remote norms like LTE - High level, Remote LAN and so forth. The primary test in MU-MIMO framework is the impedance between the co-channel clients. Subsequently, complex recipient procedure must be utilized, to decrease the co-channel obstruction.

The interest for remote throughput has filled dramatically in the beyond couple of years, with the expansion in various remote gadgets and number of new versatile clients. The throughput is the result of Data transfer capacity (Hz) and Uearthly proficiency (bits/s/Hz) [1]. Bandwidth or spectral efficiency must be increased to increase throughput. Since expanding the Data transfer capacity is an expensive component, the phantom productivity must be thought about. It very well may be expanded by utilizing various radio wires at the transmitter and recipient. Numerous Info Various Result (MIMO) radio wires improve both correspondence dependability as well as the limit of correspondence (by sending various information in various radio wires). For the most part MIMO frameworks are separated into two classifications: Highlight Point MIMO and Multi Client - MIMO (MU-MIMO) [2], [3]. In Highlight Point MIMO, both the transmitter and collector are furnished with different recieving wires. The exhibition gain can be accomplished by utilizing the procedures, for example, beamforming and spatial multiplexing of a few information streams. The wireless

channel, on the other hand, is shared spatially between users in MU-MIMO. The clients in the cell communicate and get information without joint encoding and joint recognition among them. The Base Station (BS) discusses at the same time with every one of the clients, by taking advantage of the distinction in spatial marks at the BS receiving wire cluster. MIMO frameworks are consolidated in a few new age remote norms like LTE - High level, Remote LAN and so forth. The primary test in MU-MIMO framework is the impedance between the co-channel clients. Subsequently, complex recipient procedure must be utilized, to decrease the co-channel obstruction. In [4], it is shown that by involving an endless number of radio wires at the BS in examination with the quantity of clients in the cell, the irregular channel vectors among clients and the BS become pair-wise symmetrical. Uncorrelated noise and intracellular interference are eliminated and small-scale fading is averaged out by adding more antennas to the BS. Subsequently, basic matched channel handling at BS is ideal. Massive MIMO system or large antenna array MU-MIMO system is a type of MU-MIMO system that has hundreds of antennas at the base station and serves numerous single-antenna user terminals simultaneously at the same frequency and time [5, 6]. One of the designs proposed for 5G remote correspondence is the huge MIMO framework in which BS is outfitted with an enormous number of radio wires and serves numerous single radio wire client terminals as displayed in Fig 1.

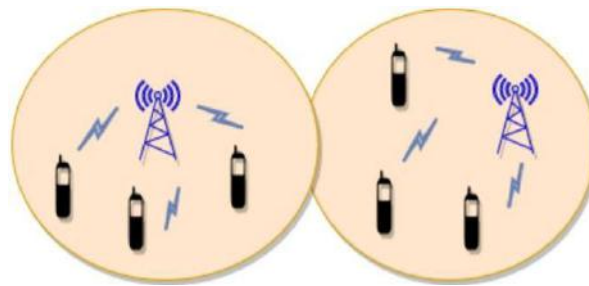

Figure 1: Multi-cell Massive MIMO System

Advantages of Massive MIMO System:-

High energy efficiency: If the channel is estimated from the uplink pilots, then each user's transmitted power can be reduced proportionally to $1/\sqrt{M}$ considering M is very large. If perfect Channel State Information (CSI) is available at the BS, then the transmitted power is reduced proportionally to $1/M$ [7]. In the downlink case, the BS can send signals only in the directions where the user terminals are located. By using the Massive MIMO, the radiated power can be reduced achieving high energy efficiency.

- **Simple signal processing:** Using an excessive number of BS antennas compared to users lead to the pair-wise orthogonality of channel vectors. Hence, with simple linear processing techniques both the effects of inter user interference and noise can be eliminated.
- **Sharp digital beamforming:** With an antenna array, generally analog beamforming is used for steering by adjusting the phases of RF signals. But in the case of Massive MIMO, beamforming is digital because of linear precoding. Digital beamforming is performed by tuning the phases and amplitudes of the transmitted signals in baseband. Without steering actual beams into the channels, signals add up in phase at the intended users and out of phase at other users. With the increase in a number of antennas, the signal strength at the intended users gets higher and provides low interference from other users. Digital beamforming in massive MIMO provides a more flexible and aggressive way of spatial multiplexing. Another advantage of digital beamforming is that it does not require array calibration since reciprocity is used.
- **Channel hardening:** The channel entries become almost deterministic in case of Massive MIMO, thereby almost eliminating the effects of small scale fading. This will significantly reduce the channel estimation errors.
- **Reduction of Latency:** Fading is the most important factor which impacts the latency. More fading will leads to more latency. Because of the presence of Channel hardening in Massive MIMO, the effects of fading will be almost eliminated and the latency will be reduced significantly.
- **Robustness:** Robustness of wireless communications can be increased by using multiple antennas. Massive MIMO have excess degrees of freedom which can be used to cancel the signal from intentional jammers.

- **Array gain:** Array gain results in a closed loop link budget enhancement proportional to the number of BS antennas.
- **Good Quality of Service (QoS):** Massive MIMO gives the provision of uniformly good QoS to all terminals in a cell because of the interference suppression capability offered by the spatial resolution of the array. Typical baseline power control algorithms achieve max-min fairness among the terminals.
- **Autonomous operation of BS's:** The operation of BS's is improved because there is no requirement of sharing Channel State Information (CSI) with other cells and no requirement of accurate time synchronization.

2. MASSIVE MIMO CONCEPT:

A single cell massive MIMO system where BS is equipped with a large number of antennas (M) and serving multiple single antenna User Terminals (K), where ($M > K$) is shown in Figure 1. The channel matrix of massive MIMO system is modeled as the product of small scale fading matrix and a diagonal matrix of geometric attenuation and log-normal shadow fading. The channel coefficient between the m^{th} antenna of the BS and the k^{th} user h_{mk} is represented by

$$h_{mk} = g_{mk} \sqrt{\beta_k} \quad (1)$$

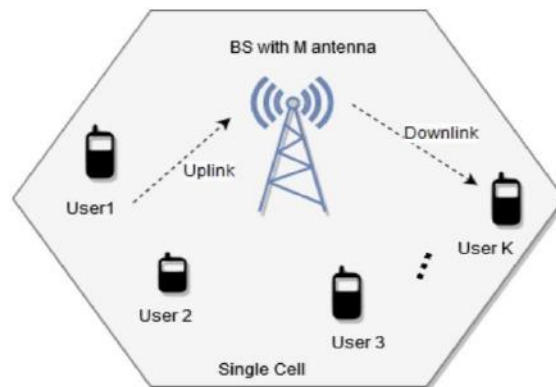

Figure 2: Single cell Massive MIMO System

Where g_{mk} is the small scale fading coefficient. $\sqrt{\beta_k}$ models the geometric attenuation and shadow fading, which is assumed to be independent over m and to be constant over many coherence time intervals and known a priori. This assumption is reasonable since the distance between the users and base station is much larger than the distance between the antennas.

Challenges

Propagation Model: In most of the Massive MIMO related works, the assumption that made was: as the BS antennas grow the user channels are uncorrelated and the channel vectors become pair-wise orthogonal. But in real time propagation environment, antenna correlation comes into the picture. If the antennas are highly correlated, then the channel vectors cannot become pair-wise orthogonal by increasing the number of antennas. This means that users location is an important factor in Massive MIMO systems.

Modulation: For the construction of a BS with a large number of antennas, cheap power efficient RF amplifiers are needed.

Channel Reciprocity: TDD operation depends on channel reciprocity. There seems to be a reasonable consensus that the propagation channel itself is basically reciprocal unless the propagation is suffering from materials with strange magnetic properties. Between the uplink and the downlink, there is a hardware chain in the base station and terminal transceivers may not be reciprocal.

Channel Estimation: To perform detection at the receiver side, we need perfect CSI at the receiver side. Due to the mobility of users in MU case, channel matrix changes with time. In high mobility case, accurate and time acquisition of CSI is very difficult. FDD Massive MIMO induces training overhead and TDD Massive MIMO relies on channel reciprocity and training may occupy a large fraction of the coherence interval.

Low-cost Hardware: Large number of RF chains, Analog- to-Digital converters, Digital-to-Analog converters are needed.

Coupling between antenna arrays: At the BS side, several antennas are packed in a small space. This causes mutual coupling in between the antenna arrays. Mutual coupling degrades the performance of Massive MIMO due to power loss and results in lower capacity and less number of degrees of freedom. When designing a Massive MIMO system, the effect of mutual coupling has to be taken into account [8], [9].

Mobility: If the mobility of the terminal is very high, then the coherence interval between the channel becomes very less. Therefore, it accommodates very less number of pilots. Pilot Contamination: Pilot contamination is a challenging problem for multicell massive MIMO is to be resolved. In multicell system, users from neighboring cells may use non-orthogonal pilots that result in pilot contamination. This causes inter-cell interference problem which further grows with the increase in a number of BS antennas.

3. SPECTRUM SENSING:

A major challenge in cognitive radio is that the secondary users need to detect the presence of primary users in a licensed spectrum and quit the frequency band as quickly as possible if the corresponding primary radio emerges in order to avoid interference to primary users. This technique is called spectrum sensing. Spectrum sensing and estimation is the first step to implement Cognitive Radio system [5]. We can categorize spectrum sensing techniques into direct method, which is considered as frequency domain approach, where the estimation is carried out directly from signal and indirect method, which is known as time domain approach, where the estimation is performed using autocorrelation of the signal. Another way of categorizing the spectrum sensing and estimation methods is by making group into model based parametric method and period gram based nonparametric method.

- a. Primary transmitter detection: In this case, the detection of primary users is performed based on the received signal at CR users. This approach includes matched filter (MF) based detection, energy based detection, covariance based detection, waveform based detection, cyclostationary based detection, radio identification based detection and random Hough Transform based detection.
- b.
- c. Cooperative and collaborative detection: In this approach, the primary signals for spectrum opportunities are detected reliably by interacting or cooperating with other users, and the method can be implemented as either centralized access to spectrum coordinated by a spectrum server or distributed approach implied by the spectrum load smoothing algorithm or external detection.

Figure 3 shows the detailed classification of spectrum Sensing techniques. They are broadly classified into three main types, transmitter detection or non-cooperative sensing, cooperative sensing and interference based sensing. Transmitter detection technique is further classified into energy detection, matched filter detection and cyclostationary feature detection [6].

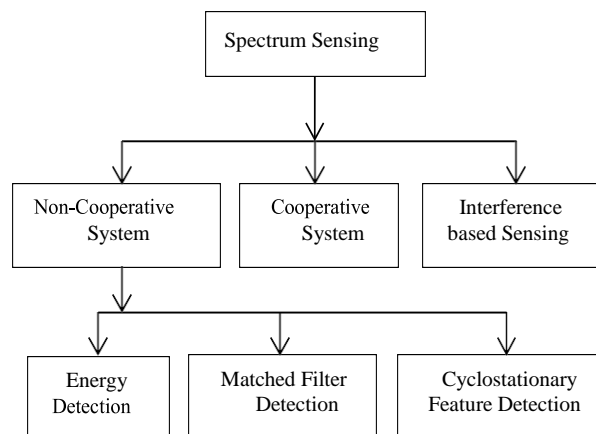

Figure 3: Classification of spectrum sensing techniques

Non-cooperative Spectrum Sensing

Since it is difficult to sense the status of the primary receiver, so to detect the primary user transmission it is necessary to detect the signals sent by the primary transmitter. This kind of spectrum sensing is also called primary transmitter detection.

Energy Detection

If CR users have no information about the primary signals then energy detection can be used for spectrum sensing. ED is optimal detector if noise power is known to the CR user [2]. Energy detection is very simple and easy to implement. It is the most popular spectrum sensing technique. In energy detection, the presence of the signal is detected by measuring the signal over an observation time.

Advantages: Simple and fewer complexes than other techniques No prior knowledge of the primary signal required Easy to implement

Disadvantages: High sensing time required to achieve the desired probability of detection Using ED, it is not easy to distinguish Primary Signal from noise signal Detection performance is limited by noise uncertainty Spread spectrum signals cannot be detected by ED.

Matched Filter

Detection In matched filter detection SNR of the received signal is maximized. The CR user needs to have the prior knowledge of the primary signal transmitted by the primary user. This is the basic requirement for the matched filter detection. Matched filter operation defines a correlation in which unknown signal is convolved with the filter whose impulse response is the mirror and time shifted versions of a reference signal [6].

Advantages: It needs less detection time. When information of the primary user signal is known to the CR user then Matched Filter Detector is optimal detector in stationary Gaussian noise [3].

Disadvantages: It needs priori knowledge of the received signal, high complexity.

Cyclostationary Feature Detection

The modulated signals are generally cyclostationary in nature and this kind of feature of these signals can be used in this technique to detect the signal. A cyclostationary signals have the statistical properties that vary periodically with time [7]. This periodicity is used to identify the presence or absence of primary users. Due to the periodicity, these cyclostationary signals exhibit the features of periodic statistics and spectral correlation, which is not found in stationary noise [8].

Advantages: Robust to noise uncertainties and better performance in low SNR regions. Capable of distinguishing the CR transmissions from various types of PU signals. No synchronization required Improves the overall CR throughput

Disadvantages: Highly complex method long sensing time

4. PROPOSED METHODOLOGY:

The implementation of system model in MATLAB software, with the main block described below. We generated a random binary signal in serial manner. To analyze a signal in the serial to parallel converter then applied IFFT (inverse fast fourier transform) and convert it from parallel to serial OFDM signal.

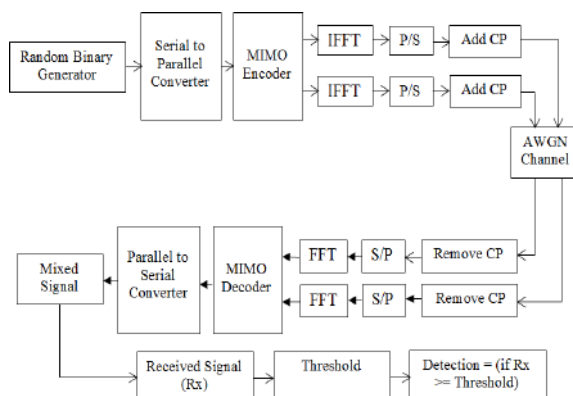

Figure 4: Design of MIMO-OFDM System using Matched Filter Spectrum Sensing Cognitive Radio Network

The OFDM signal is add cyclic prefix (CP) because the remove interference between OFDM symbols. We then feed this signal through an Additive White Gaussian Noise (AWGN) channel. At the receiver site, the OFDM signal is CP removed and signal converted from serial to parallel then applied FFT (fast fourier transform). Received the output of FFT signal then signal converted from parallel to serial converter to each symbol for analysis in the frequency domain is received. After demodulation the signal is cross correlated with that a time shifted in demodulation signal.

Finally, the received signal is compared to a threshold value (λ) following the SNR or determines whether the signal is absent or present; if the received signal is greater than the threshold value, there will be detection, otherwise not:

5. SIMULATION RESULT:

Simulation experiments are conducted to evaluate the SNR VS Bit Error Rate (BER) performance of the proposed matched filter detection spectrum sensing 8×8 system is shown in figure 5.

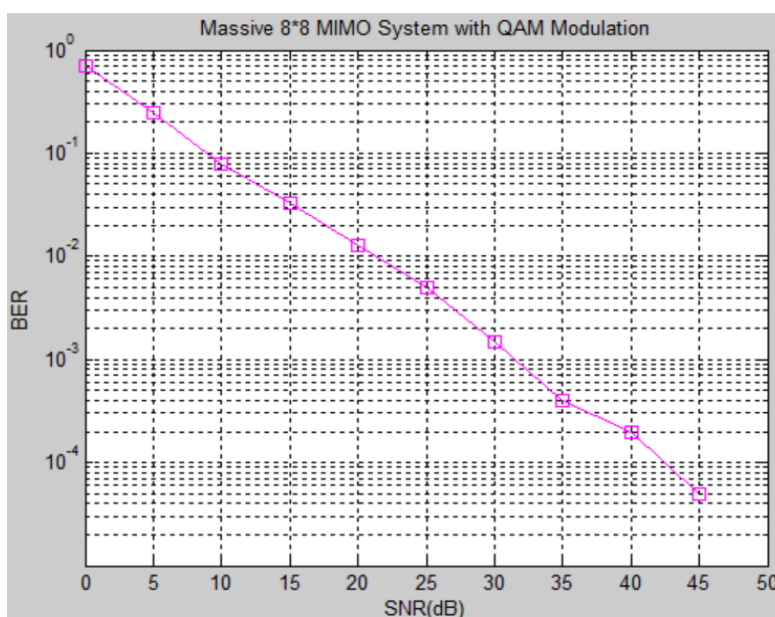

Figure 5: BER vs SNR for Matched Filter Detection Spectrum Sensing 8×8 System

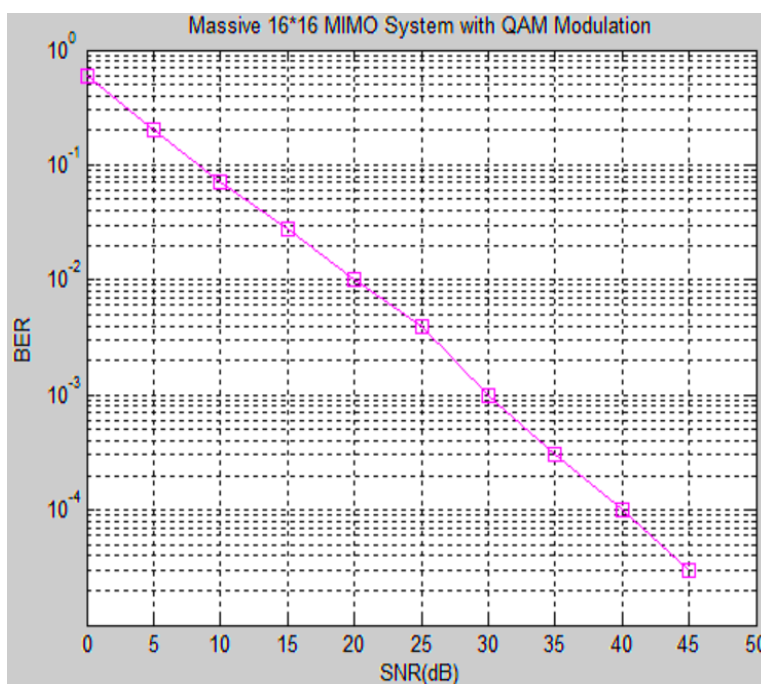

Figure 6: BER vs SNR for Matched Filter Detection Spectrum Sensing 16×16 System

Simulation experiments are conducted to evaluate the SNR VS BER performance of the proposed matched filter detection spectrum sensing 16×16 system is shown in figure 6.

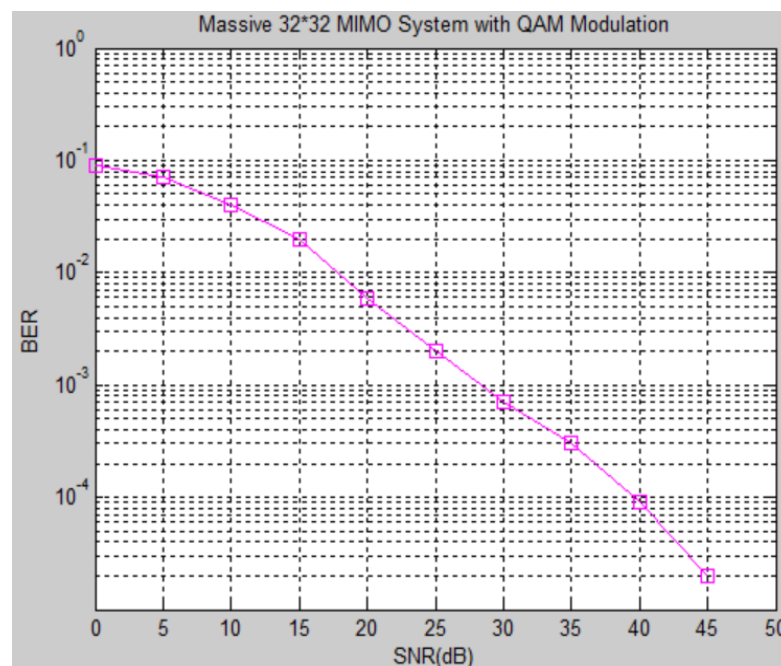

Figure 7: BER vs SNR for Matched Filter Detection Spectrum Sensing 32×32 System

Simulation experiments are conducted to evaluate the SNR VS BER performance of the proposed matched filter detection spectrum sensing 32×32 system is shown in figure 7.

6. CONCLUSION:

A matched filter, also known as optimal linear filter, is a spectrum-sensing method that detects the free portion of the primary user's spectrum and allocates it to secondary users. It derives from cross-correlating an unknown signal with known ones to detect the unknown signal's presence based on its SNR. In matched-filter detection, the dynamic threshold is used to improve the spectrum-sensing efficiency and provide better performance in cases of lower SNR.

REFERENCES:

1. Supraja Eduru and Nakkeeran Rangaswamy, "BER Analysis of Massive MIMO Systems under Correlated Rayleigh Fading Channel", 9th ICCCNT IEEE 2018, IISC, Bengaluru, India.
2. H. Al-Hraishawi, G. Amarasuriya, and R. F. Schaefer, "Secure communication in underlay cognitive massive MIMO systems with pilot contamination," in In Proc. IEEE Global Commun. Conf. (Globecom), pp. 1–7, Dec. 2017.
3. V. D. Nguyen et al., "Enhancing PHY security of cooperative cognitive radio multicast communications," IEEE Trans. Cognitive Communication And Networking, vol. 3, no. 4, pp. 599–613, Dec. 2017.
4. R. Zhao, Y. Yuan, L. Fan, and Y. C. He, "Secrecy performance analysis of cognitive decode-and-forward relay networks in Nakagami-m fading channels," IEEE Trans. Communication, vol. 65, no. 2, pp. 549–563, Feb. 2017.
5. W. Zhu, J. and. Xu and N. Wang, "Secure massive MIMO systems with limited RF chains," IEEE Trans. Veh. Technol., vol. 66, no. 6, pp. 5455–5460, Jun. 2017.
6. W. Wang, K. C. Teh, and K. H. Li, "Enhanced physical layer security in D2D spectrum sharing networks," IEEE Wireless Communication Letter, vol. 6, no. 1, pp. 106–109, Feb. 2017.
7. J. Zhang, G. Pan, and H. M. Wang, "On physical-layer security in underlay cognitive radio networks with full-duplex wireless-powered secondary system," IEEE Access, vol. 4, pp. 3887–3893, Jul. 2016.
8. R. Zhang, X. Cheng, and L. Yang, "Cooperation via spectrum sharing for physical layer security in device-to-device communications under laying cellular networks," IEEE Trans. Wireless Communication, vol. 15, no. 8, pp. 5651–5663, Aug. 2016.
9. K. Tourki and M. O. Hasna, "A collaboration incentive exploiting the primary-secondary systems cross interference for PHY security enhancement," IEEE J. Sel. Topics Signal Process., vol. 10, no. 8, pp. 1346–1358, Dec. 2016.
10. T. Zhang et al., "Secure transmission in cognitive MIMO relaying networks with outdated channel state information," IEEE Access, vol. 4, pp. 8212–8224, Sep. 2016.

11. Y. Huang et al., "Secure transmission in spectrum sharing MIMO channels with generalized antenna selection over Nakagami-m channels," *IEEE Access*, vol. 4, pp. 4058–4065, Jul. 2016.
12. Y. Deng et al., "Artificial-noise aided secure transmission in large scale spectrum sharing networks," *IEEE Trans. Communication*, vol. 64, no. 5, pp. 2116–2129, May 2016.
13. Aparna Singh Kushwah, Monika Jain, "Performance Enhancement of MIMO-OFDM System based on Spectrum Sensing Cognitive Radio Networks using Matched Filter Detection", *International Journal of Innovative Research in Computer and Communication Engineering*, Vol. 6, Issue 6, June 2018.
14. Aparna Singh Kushwah, Alok Kumar Shukla, "BER Reduction of Distributed Spatial Modulation in Cognitive Relay Network based MIMO-OFDM System", *International Journal of Innovative Research in Computer and Communication Engineering*, Vol. 6, Issue 6, June 2018.
15. Shan Jin and Xi Zhang, "Compressive Spectrum Sensing for MIMO-OFDM Based Cognitive Radio Networks", *2015 IEEE Wireless Communications and Networking Conference (WCNC), Applications, and Business*, Vol. 27, No. 2, pp. 567-572, 2015.